



HILLS HERITAGE™ HOIST
MODELS 4, 5 & 6
OWNERS MANUAL

IMPORTANT: READ OWNERS MANUAL AND WARNINGS BEFORE ASSEMBLING AND USING THIS PRODUCT.

“PATENTS & REGISTERED DESIGNS APPLY TO THIS PRODUCT”

BOLT CHART

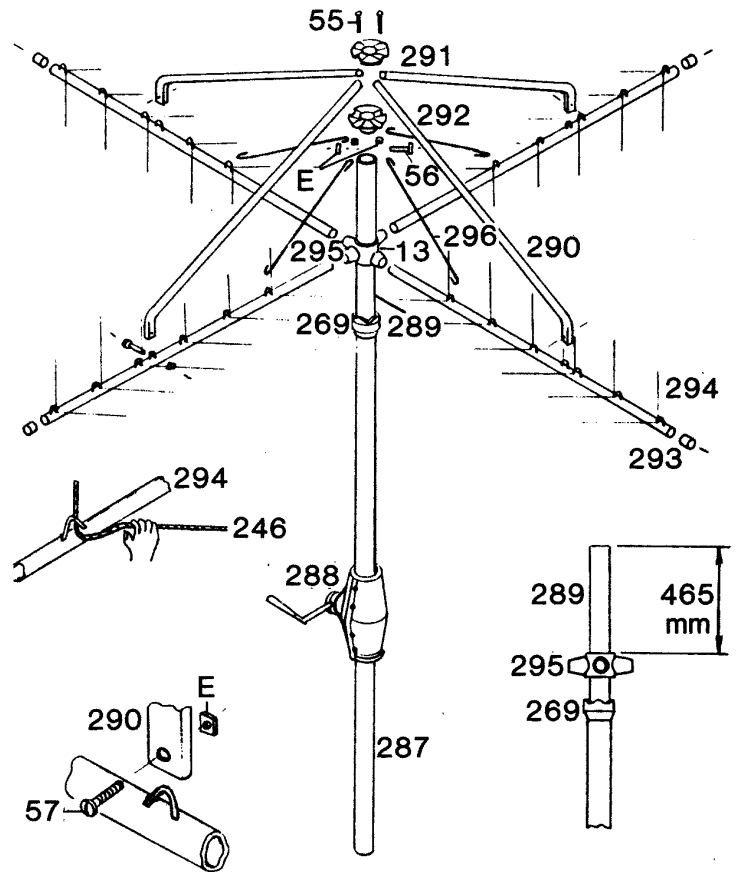
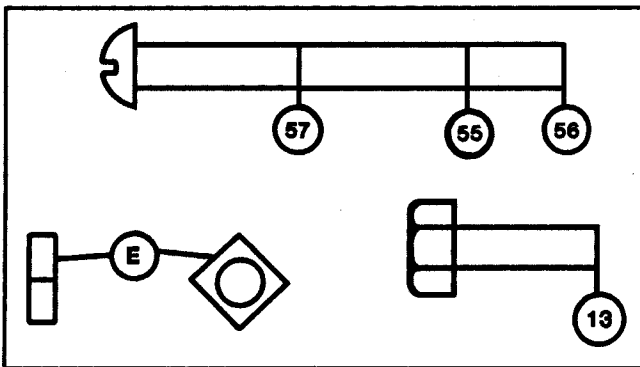

ASSEMBLY INSTRUCTIONS

1. Select a suitable site near to the laundry with about 1 metre clear on all sides of the area covered by the hoist. Dig a hole 800mm deep and 200mm in diameter. Place 150mm dry gravel in hole, and then the Main Standard (287).
NOTE: Indents downwards.

2. Stand the MAIN STANDARD upright to check convenient height for operator. Add or remove gravel so that teeth of Reducer (269) is about 75mm above the head.
3. Mix concrete to the following proportions: 3 GRAVEL : 2 SAND : 1 CEMENT. IMPORTANT - CONCRETE MUST BE MIXED FAIRLY DRY. OTHERWISE THE MAIN STANDARD WILL NOT STAY ERECT.
4. Concrete the Main Standard in position and ram the concrete tight. Check for perpendicular. Slope the surface away from the post to provide for water run-off. Finish off with fine cement.

DO NOT USE FOR 48 HOURS - SO THAT THE CONCRETE MAY HARDEN PROPERLY.

5. Fit CROSS (295) to SECONDARY STANDARD (289) and secure 465mm from TOP of Secondary Standard to TOP of Cross. Use Set Screw 13" making sure to position bolt hole in Cross (295) directly below bolt hole in TOP of Secondary Standard (289).

DO NOT FULLY TIGHTEN SCREW YET.

6. Fit top cap lower assembly (292) to secondary standard (289) using screw "56" and nut "E".
7. Fit tube stay (290) to "TEXTURE MARKED" staple on arm (294) using screw "57" and nut "E".
8. Fit arm and stay assembly (STEP 7) to hoist by placing arm into cross (295) then stay (290) into top cap assembly (291 and 292) using screw "55".

DO NOT SCREW NUT ON YET.

9. Repeat Steps 7 and 8 for other three arms.
10. INNER STAYS (296) supplied for models 5 and 6, are hooked into the innermost staples on arms (294) and positioned UNDERNEATH the Top Cap lower assembly (292). Fit nut "E" to screw "55" and tighten all nuts.
11. Fit arm caps (293) to end of arms (294).
12. Unroll the coil of wire (246) and starting with staples nearest to the centre of the HEAD PIECE, commence wiring through the staples. When wire has gone through all four staples, tie end off on the starting arm (REFER STEP 13). Taking up the slack, trace back the wire, and at each arm "kink" wire at the staple with thumb (see Diagram) making sure arms are not pulled out of line with those opposite. Finally cut wire, leaving enough to tie off onto the starting arm.
13. To tie wire off, pass wire through staple, around arm then using pliers, tension and wind end back around the wire.
14. Repeat Step 12 for all other staples working outwards from the centre.

NOTE: Tie off all wires on the same arm.

15. Ensure that the Bolts and Nuts on the gear-box covers have not worked loose during transition. Tighten if necessary.
16. HANDLE - Remove Screw and re-fit Handle right way round to pinion cover (288) - Lock with screw.
17. Raise the HEADPIECE a few turns, so that it is free to revolve. NEVER LEAVE THE HOIST WITH THE CROSS (295) AND REDUCER (269) ENGAGED. USE THIS BRAKE ONLY WHEN PEGGING OUT AND TAKING IN.
18. Lubricate as per HELPFUL HINTS Instruction 6.

HELPFUL HINTS

1. Commence hanging the washing on the inside line and work your way outwards, starting with the smallest garments.
2. The Breeze Brake (269) assists in the pegging and unpegging of clothes on windy days, by restricting the free rotation of the unit. It can be engaged by winding the unit right down.
3. To save excessive walking rotate the unit by pulling one arm and the Breeze Brake will position the next bay for loading.
4. After hanging out your washing, it is recommended that the handle be wound up one full turn (STAND IN FRONT OF THE HANDLE WHEN WINDING).
5. For faster drying and to reduce the likelihood of soiled washing, elevate fully. The rotating action gives natural spin drying of your washing.
6. To LUBRICATE your Hoist's worm gear and handle assembly:
 - a) Wind hoist to full height and apply approx. 1 teaspoon of oil through hole in elevating shaft.
 - b) Apply a few drops of oil through oil hole in gear case above handle shaft. USE ANY LIGHT GRADE OIL.

NOTE: Should the hoist squeak when revolving, wind up the HEADPIECE - smear a little bar soap on the elevating section of the Secondary Standard.

CHECK LIST

NOTE - REFER TO ASSEMBLY INSTRUCTIONS AND SKETCHES FOR PARTS LISTED BELOW

PART	PART NAME	QTY	PART	PART NAME	QTY
UL	ACCESSORY PACK HD2256	1	288	PINION COVER	1
13	5/16 BSW X 3/4 INCH HEX HEAD SET SCREW	1	289	SECONDARY STANDARD	1
246	CLOTHES WIRE FAMILY 3, 4, 5 & 6	1	290	SUPA TUBE STAY SHORT OR LONG	4
269	REDUCER	1	294	ARM ASSEMBLY FAMILY 3, 4, 5 & 6	4
287	BOTTOM MAIN STANDARD	1	295	CROSS	1
			296	INNER ROD STAY - SHORT (MODELS 5 & 6 ONLY)	4

IN THE ACCESSORY PACK (HD2256) ARE:

PART	PART NAME	QTY	PART	PART NAME	QTY
E	1/4 BSW SQUARE PRESSED NUT	9	291	TOP CAP UPPER	1
55	1/4 BSW x 1 3/4 INCH RHMT SCREW	4	292	TOP CAP LOWER ASSEMBLY	1
56	1/4 BSW x 2 1/4 INCH RHMT SCREW	1	293	ARM CAP	4
57	1/4 BSW x 7/8 INCH RHMT SCREW	4			

NOTE: PARTS 269, 287, 288, 289, 295 & "13" ARE SUPPLIED ASSEMBLED

SPARE PARTS AVAILABLE FROM YOUR STOCKIST:

HANDLE ASSEMBLY (8 BOLT MS).....ORDER FD900586	PINION CASE (8 BOLT MS).....ORDER FD900738	BOTTOM MAIN STANDARD.....ORDER FD901046
CROWN WHEEL (8 BOLT MS).....ORDER FD900608	PLAIN CASE (8 BOLT MS).....ORDER FD900754	TOP MAIN STANDARD.....ORDER FD901054
WORM ASSEMBLY (8 BOLT MS).....ORDER FD900624	FASTENER KIT (8 BOLT MS).....ORDER FD900770	CLOTHES WIRE MODEL 4.....ORDER FD901070
CROSS (8 BOLT MS).....ORDER FD900640	ARM CAP.....ORDER FD900834	PINION ASSEMBLY KIT.....ORDER FD900704
SUPA C REDUCER.....ORDER FD900666	TOP CAP SUPA.....ORDER FD900868	ARM ASSEMBLY MODEL 4.....ORDER FD900998
THRUST RING.....ORDER FD900682	SECONDARY STANDARD.....ORDER FD900980	SUPA SHORT TUBE STAY FORMED (MODELS 3 & 4).....ORDER FD901020
ARM ASSEMBLY MODEL 6.....ORDER FD901012	CLOTHES WIRE MODEL 5 & 6.....ORDER FD901096	SUPA LONG TUBE STAY FORMED (MODELS 5 & 6).....ORDER FD901038
INNER STAY SHORT MODELS 5 & 6.....ORDER FD900964	ARM ASSEMBLY MODEL 5.....ORDER FD901004	

IMPORTANT: Please retain this owners manual for spare parts identification. Record the following information from the coloured label on the wire pack for future reference.

Product Number:.....

Record date of purchase:.....

Name and location of store:.....

WARNINGS

DO NOT ALLOW CHILDREN OR PETS TO SWING ON THE ROTARY CLOTHES HOIST OR ITEMS OF LAUNDRY.

DO NOT WIND DOWN QUICKLY. ENSURE WHEN RAISING AND LOWERING YOUR ROTARY CLOTHES HOIST THAT BYSTANDERS (IN PARTICULAR CHILDREN) ARE WELL CLEAR.

DO NOT USE FOR ANY OTHER PURPOSE OTHER THAN TO HANG AND DRY WASHING.

DO NOT USE YOUR ROTARY CLOTHES HOIST IF PARTS ARE WORN OR DAMAGED.

HILLS GUARANTEE

HILLS INDUSTRIES LIMITED undertake that if any part of its manufacture has failed to operate correctly due to faulty workmanship or defective material, it will repair or replace the part free of cost for a period of TEN (10) years from the date of purchase of the article, given fair wear and tear. Evidence of unfair usage or incorrect adjustment by the owner will void this promise.

HILLS INDUSTRIES LIMITED will not be responsible for any costs in connection with freight or postage, or for the expenditure necessary to dismantle the article, replace the part in position and re-assemble the article.

This guarantee is in addition to any rights or remedies conferred on the consumer by the Trades Practices Act or state laws.

As a proudly Australian manufacturer, we are committed to provide you complete customer satisfaction. If you have questions about this product, or find there are missing or damaged parts. PLEASE CALL Hills direct on **1300 300 819** (cost of a local call) for assistance during normal business hours.

HILLS INDUSTRIES LIMITED do not recommend the application of a 'canopy' on any of their outdoor dryer range.

Unless any addition or attachment to this product has HILLS specific approval or is sold as a HILLS product the warranty on this product is waived. This product is designed to perform a specific task under established test loads and unauthorised attachments may produce stresses for which the design is not appropriate.

Design, specifications and colours are subject to change without notice.

HILLS INDUSTRIES LIMITED

A.B.N. 35 007 573 417

ISSUE 06/01/05