

## HILLS GUARANTEE

HILLS INDUSTRIES LIMITED undertake that if any part of its manufacture has failed to operate correctly due to faulty workmanship or defective material, it will repair or replace the part free of cost for a period of TEN (10) years from the date of purchase of the article, given fair wear and tear. The line is also guaranteed for a period of one (1) year. Evidence of unfair usage or incorrect adjustment by the owner will void this promise.

HILLS INDUSTRIES LIMITED will not be responsible for any costs in connection with freight or postage, or for the expenditure necessary to dismantle the article, replace the part in position and re-assemble the article.

This guarantee is in addition to any rights or remedies conferred on the consumer by the Trades Practices Act or state laws.

As a proudly Australian manufacturer, we are committed to provide you complete customer satisfaction. If you have questions about this product, or find there are missing or damaged parts. PLEASE CALL Hills direct on **1300 300 819** (cost of a local call) for assistance during normal business hours.

HILLS INDUSTRIES LIMITED do not recommend the application of a 'canopy' on any of their outdoor dryer range.

Unless any addition or attachment to this product has HILLS specific approval or is sold as a HILLS product the warranty on this product is waived. This product is designed to perform a specific task under established test loads and unauthorised attachments may produce stresses for which the design is not appropriate.

*Design, specifications and colours are subject to change without notice.*

### HILLS INDUSTRIES LIMITED

A.B.N. 35 007 573 417

ISSUE 31/10/00

**IMPORTANT:** Please retain this owners manual for spare parts identification. Record the following information from the carton for future reference.

Product Number: FD.....

Record date of purchase.....

Name and location of store.....



PARALINE - DUO <sup>PLUS</sup>   
GLIDE LIFT  WITH LINE TENSIONING <sup>TM</sup>

"Designed not to be noticed"

## OWNER'S MANUAL

**IMPORTANT: READ OWNER'S MANUAL AND WARNINGS BEFORE ASSEMBLING AND USING THIS PRODUCT**

"PATENTS AND REGISTERED DESIGNS APPLY TO THIS PRODUCT"

RD13106d

## HOW TO OPERATE

### TO FOLD OUT

**NOTE:** THE OPERATION OF THE SMALLER INNER FRAME IS THE SAME AS THE LARGER OUTER FRAME.

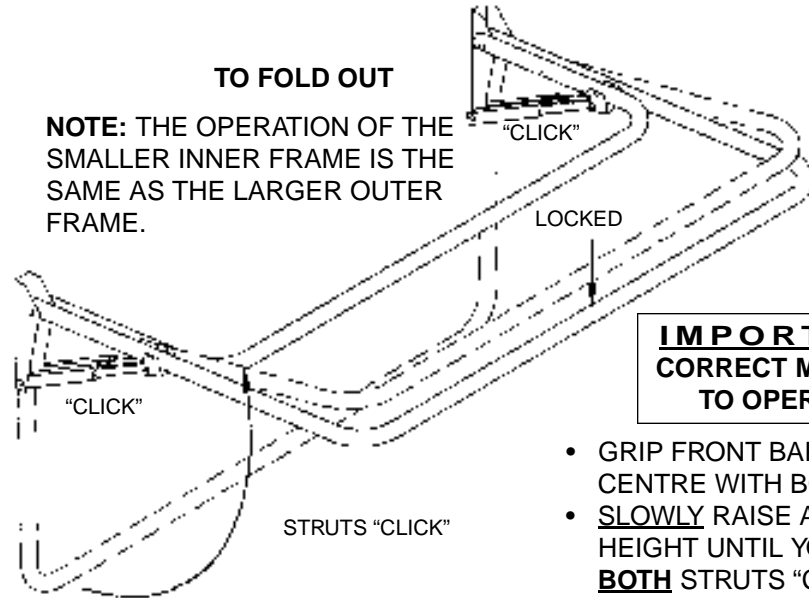

### IMPORTANT CORRECT METHOD TO OPERATE

- GRIP FRONT BAR IN THE CENTRE WITH BOTH HANDS.
- **SLOWLY** RAISE ABOVE HEAD HEIGHT UNTIL YOU HEAR **BOTH** STRUTS "CLICK".
- LOWER SLIGHTLY UNTIL STRUTS LOCK.

### TO FOLD DOWN

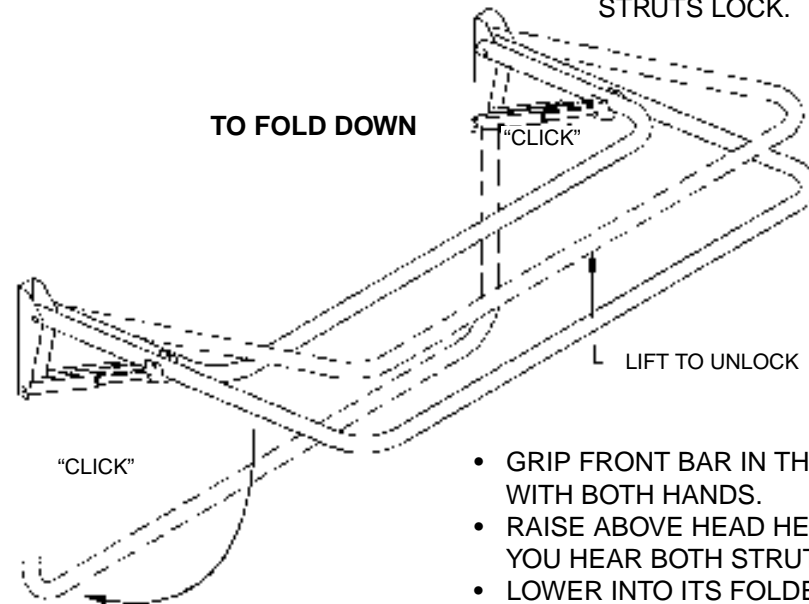

- GRIP FRONT BAR IN THE CENTRE WITH BOTH HANDS.
- RAISE ABOVE HEAD HEIGHT UNTIL YOU HEAR BOTH STRUTS "CLICK".
- LOWER INTO ITS FOLDED POSITION.

**NOTE:** Raising frame other than from centre may result in only 1 strut locking. If this occurs, raise frame on locked side only until locked strut "clicks", then lower into folded position.

## WARNINGS — MAINTENANCE

### WARNINGS

- DO NOT** ALLOW CHILDREN OR PETS TO SWING ON THE PARALINE OR ITEMS OF LAUNDRY.
- DO NOT** UNLOCK AND ALLOW TO DROP DOWN UNCONTROLLED.
- DO NOT** USE FOR ANY PURPOSE OTHER THAN TO HANG AND DRY WASHING.
- \* INJURY MAY OCCUR FROM THE MISUSE OF THIS PRODUCT.
- \* ENSURE WHEN RAISING AND LOWERING YOUR PARALINE THAT BYSTANDERS (IN PARTICULAR CHILDREN) ARE WELL CLEAR.

### MAINTENANCE

- \* **LINE TENSIONING:** REMOVE EXCESSIVE SLACK FROM THE LINES BY STARTING AT ONE TIE OFF POINT AND WORKING THE SLACK LINES TOWARDS THE SECOND TIE OFF POINT. UNTIE THE LINE AND PULL THE ACCUMULATED SLACK LINE THROUGH THE LINE TENSIONER AND RE-TIE. SEE DIAGRAM 9. **IMPORTANT** DO NOT OVER TENSION THE LINE AS THIS MAY BOW THE END FRAMES.
- \* WE **DO NOT** RECOMMEND THE USE OF OIL OR "WD" TYPE LUBRICANTS ON ANY PART OF THE PARALINE.
- \* WIPE AWAY ANY DIRT AND DUST FROM THE TELESCOPIC STRUTS WITH A DAMP CLOTH ONCE A MONTH. MORE REGULARLY IN DUSTY CONDITIONS.
- \* INSPECT YOUR PARALINE REGULARLY FOR SIGNS OF DAMAGE OR WEAR. **DO NOT** USE YOUR PARALINE IF PARTS ARE WORN OR DAMAGED. **CONSULT YOUR LOCAL HILLS CUSTOMER SERVICE DIVISION FOR REPLACEMENT PARTS. REFER TO THE LIST BELOW FOR REQUIRED REPLACEMENTS.**
- \* TO MAINTAIN THE APPEARANCE AND DURABILITY OF THE COATING ON THE METAL COMPONENTS WE RECOMMEND A TWICE YEARLY APPLICATION OF A REPUTABLE BRAND OF CAR POLISH OR WAX.

## CHECK LIST

	PARTS DESCRIPTION	QTY
CONTENTS OF CARTON	END FRAME TUBES — LONG	2
	END FRAME TUBES — SHORT	2
	SPACER TUBE — LONG	1
	SPACER TUBE — SHORT	1
	PIVOT BRACKETS	4
	WALL BRACKETS	2
	TELESCOPIC STRUTS	4
	LINE	25M
	ACCESSORY BAG	1
CONTENTS OF ACCESSORY BAG	BOLT — B 5/16 BSW x 1 1/2" CH SN	4
	BOLT — C 5/16 BSW x 1 1/4" HEX	4
	BOLT — G 5/16 BSW x 4" CH SN	4
	NUT A — 5/16 UNC NYLOC	12
	WASHER — A 5/16" x 3/4" x 18g ZP	4
	END CAP — SQUARE	4
	END CAP — OVAL	4
	LINE TENSIONER	4

## SPARE PARTS

SPARE PARTS ARE AVAILABLE FROM YOUR DEALER. REFER TO THE LIST BELOW FOR REQUIRED REPLACEMENTS.

PART NAME	ORDER KIT NUMBER
POLY CORE LINE 40M — BEIGE	FD902716
LINE TENSIONER	FD901932

A MORE COMPREHENSIVE RANGE OF SPARE PARTS ARE AVAILABLE UPON REQUEST. PLEASE CALL HILLS DIRECT ON 1300 300 819 (COST OF A LOCAL CALL) FOR ASSISTANCE DURING NORMAL BUSINESS HOURS.

## FASTENER CHART

DRAWN FULL SIZE

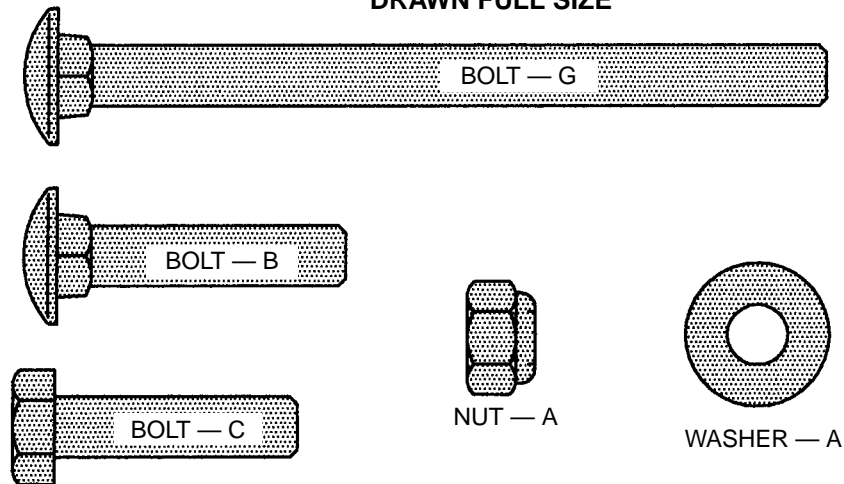

## OPTIONAL MOUNTING KITS

	ORDER KIT NUMBER
GROUND MOUNT KIT	FD45072 — SALT BUSH
GROUND MOUNT KIT	FD40782 — FEDERATION GREEN
SOCKET KIT	FD40388

# INSTALLATION: RECOMMENDED FOR BRICK WALL AND POST MOUNT ONLY

**1 SELECT A SUITABLE LOCATION**

CAN BE SHORTENED TO SUIT INSTALLATION: CUT SPACER TUBE TO DESIRED LENGTH THEN REDUCE MOUNTING HOLE CENTRES BY THE AMOUNT CUT FROM THE SPACER TUBE.

2203 mm  
1560 mm  
1000 mm  
500 mm

NO PIPES OR OBSTRUCTIONS BETWEEN BRACKETS

**2 MARK POSITION OF WALL BRACKETS**

2203mm  
STRAIGHT EDGE  
POST MOUNT HOLE  
WALL MOUNT HOLE  
SPIRIT LEVEL  
WALL BRACKET  
POST & WALL MOUNT HOLE  
WALL BRACKET  
OPTIONAL POST  
RECOMMENDED MOUNTING HEIGHT: USERS HEIGHT PLUS 50mm MINIMUM HEIGHT 1585mm  
RECOMMENDED MOUNTING HEIGHT: USERS HEIGHT PLUS 25mm MINIMUM HEIGHT 1560m  
NOTE: A MINIMUM DISTANCE OF 500MM FROM THE EAVES TO THE TOP OF THE FRAME IS REQUIRED  
(OPTIONAL) POST MOUNTING REFER TO GROUND MOUNT KIT FOR INSTALLATION DETAILS.  
MAKE ALLOWANCE FOR SLOPING GROUND

**3 DRILL HOLES FOR MASONRY ANCHORS**

**NOTE:** MASONRY ANCHORS ARE NOT INCLUDED WITH THIS PRODUCT. CONSULT YOUR LOCAL HARDWARE SPECIALIST FOR ADVICE ON WHICH MASONRY ANCHORS ARE MOST SUITABLE FOR YOUR PARTICULAR TYPE OF BUILDING STRUCTURE. DRILL HOLES IN WALL AS PER ANCHOR MANUFACTURERS DIRECTIONS.

UNIT TO BE FITTED TO WALL USING 5/16" OR 8mm DIAMETER BOLTS.

**4 FIT WALL BRACKETS**

**BEFORE TIGHTENING BOLTS ENSURE THAT THE BRACKETS ARE LEVEL AND VERTICAL**

**NOTE:** MASONRY ANCHORS ARE NOT INCLUDED WITH THIS PRODUCT. CONSULT YOUR LOCAL HARDWARE SPECIALIST FOR ADVICE ON WHICH MASONRY ANCHORS ARE MOST SUITABLE FOR YOUR PARTICULAR TYPE OF BUILDING STRUCTURE.

5

FIT SQUARE CAPS TO STRUTS AND STRUTS TO WALL BRACKETS

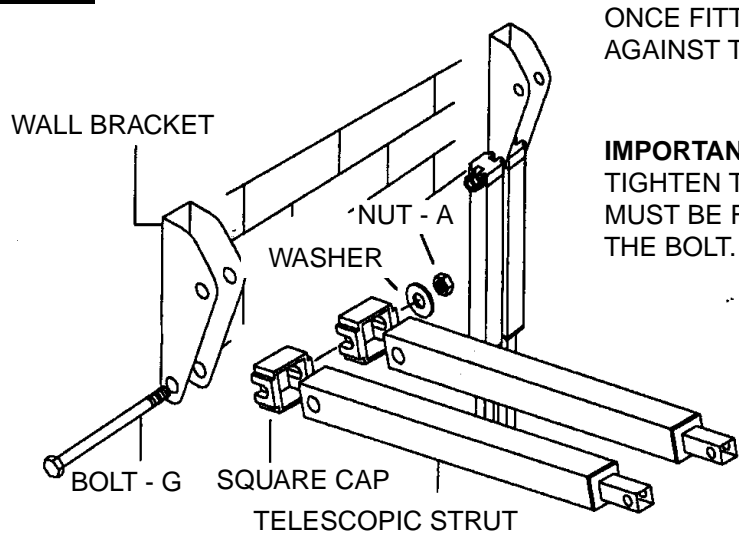

ONCE FITTED, LAY STRUT BACK AGAINST THE WALL.

**IMPORTANT:** DO NOT OVER TIGHTEN THE NUT. THE STRUTS MUST BE FREE TO PIVOT ON THE BOLT.

6

FIT LINE TENSIONERS, OVAL CAPS AND PIVOT BRACKETS TO END FRAMES. MAKE LEFT AND RIGHT HAND PAIRS.

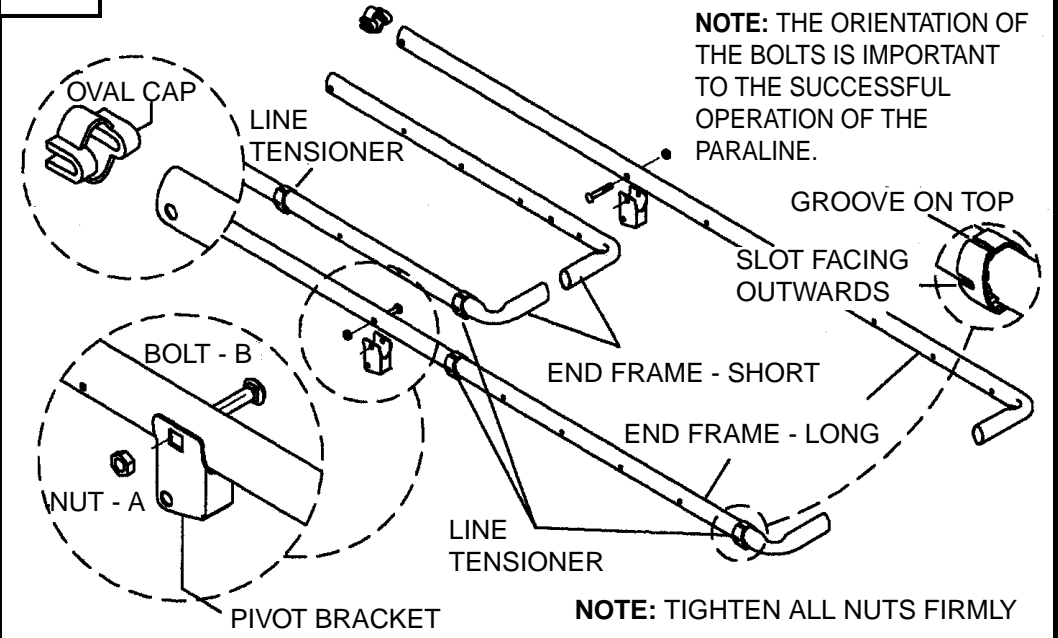

**NOTE:** THE ORIENTATION OF THE BOLTS IS IMPORTANT TO THE SUCCESSFUL OPERATION OF THE PARALINE.

**NOTE:** TIGHTEN ALL NUTS FIRMLY

7

FIT END FRAMES TO WALL BRACKETS AND STRUTS TO PIVOT BRACKETS

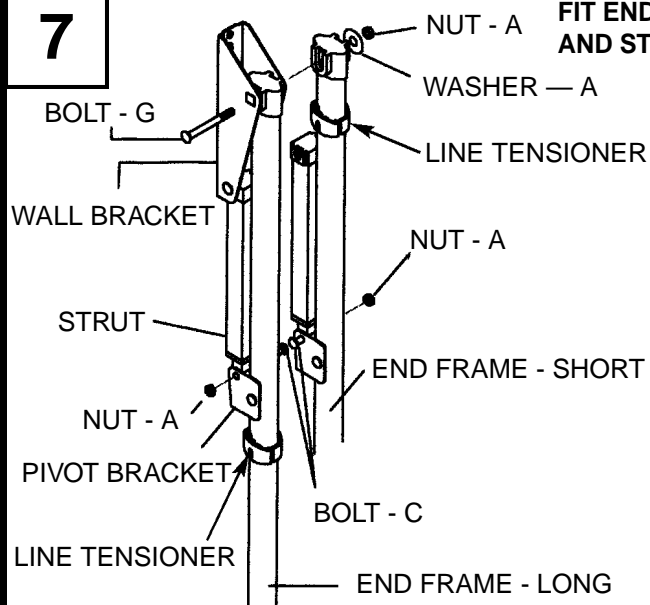

**IMPORTANT:** DO NOT OVER TIGHTEN THE NUTS. THE FRAME AND STRUT MUST BE FREE TO PIVOT ON THE BOLTS.

8

FIT SPACER TUBES TO END FRAMES

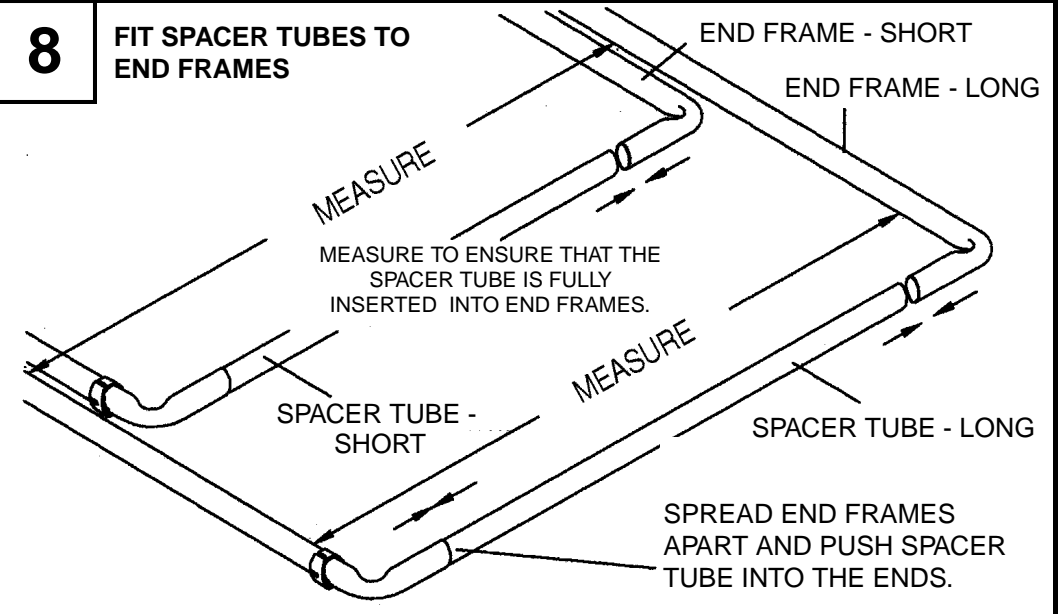

MEASURE TO ENSURE THAT THE SPACER TUBE IS FULLY INSERTED INTO THE ENDS.

SPREAD END FRAMES APART AND PUSH SPACER TUBE INTO THE ENDS.

ASSEMBLY DETAILS

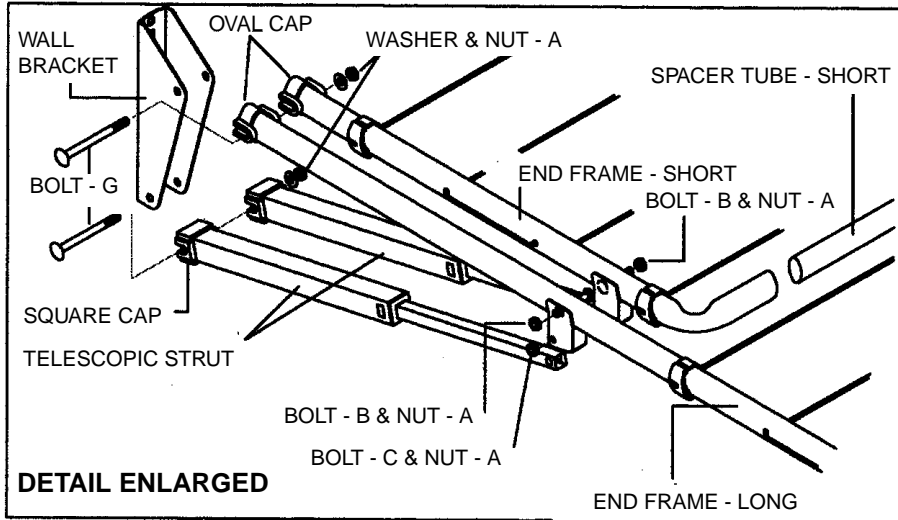

NOTE: TENSIONERS MAY BE USED ON LEFT OR RIGHT HAND SIDE OF FRAME

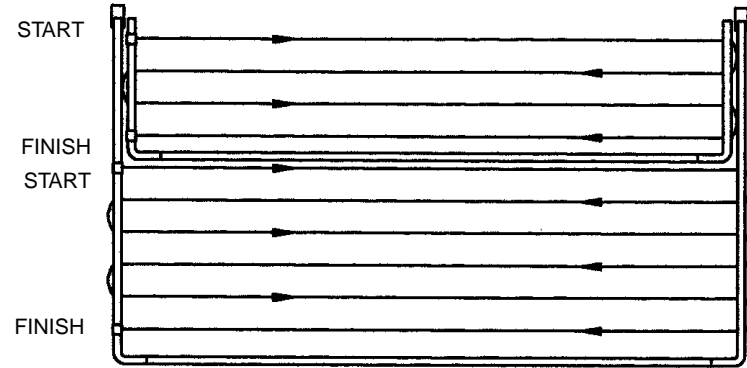

DO NOT USE THIS HOLE WHEN WIRING THE CLOTHESLINE

WIRING DETAILS  
IMPORTANT: DO NOT OVER TENSION LINE.

LINE TIE OFF METHOD  
STEP 1:  
THREAD LINE THROUGH TENSIONER AND PULL TIGHT.  
FORCE THROUGH GROOVE IN TOP.

STEP 2:  
KEEP LINE TIGHT AND THREAD THROUGH THE TWO HOLES AS SHOWN BELOW.  
TRIM OFF EXCESS LINE.

DO NOT USE THIS HOLE WHEN WIRING THE CLOTHESLINE

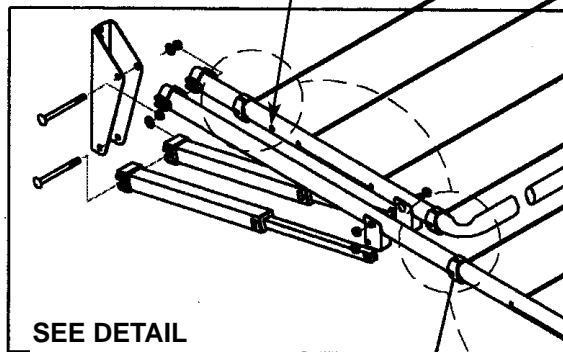

LINE TENSIONER

SPACER TUBE LONG

